



GMW
W E L D I N G



**Consumíveis para Soldagem
de Plantas de Reciclagem
de Metais.**

Garra Hidráulica



Recuperação de unha rompida:

GMW 110 MC

Revestimento Anti Abrasão:

GMW XTRA 600 MC

Capa do Rotor

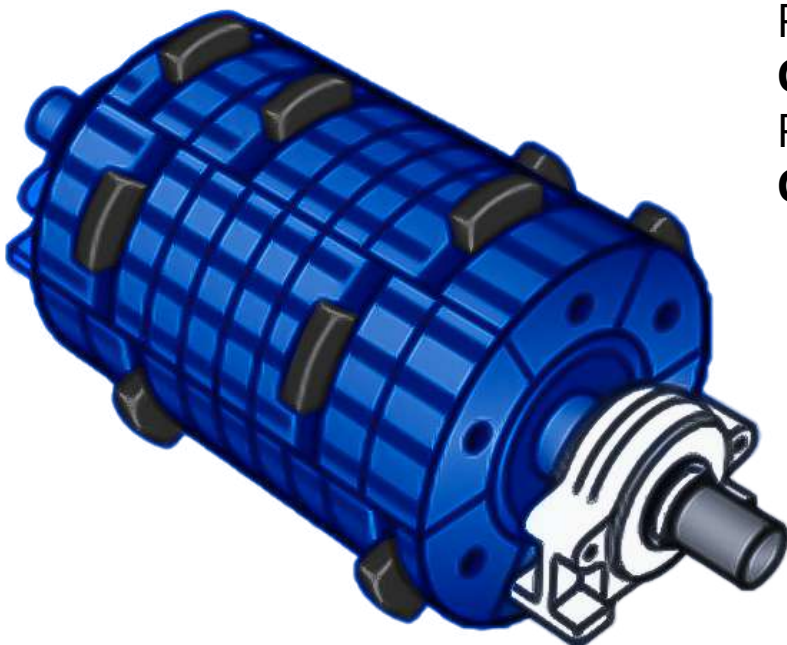

Recuperação Standard:

GMW XTRA 600 MC

Recuperação Premium:

GMW HAMMER MN OA

Martelo

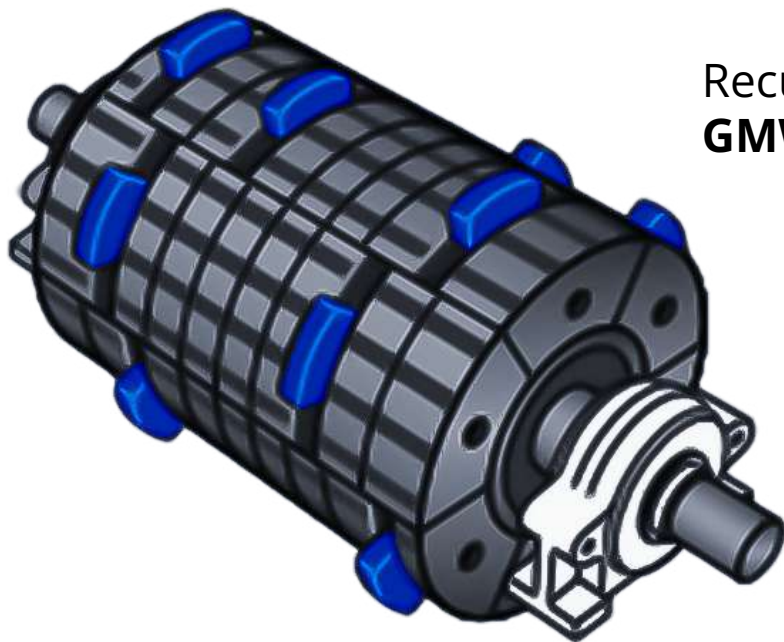

Recuperação de Martelo:
GMW XTRA HAMMER MN OA



Rolo Alimentador

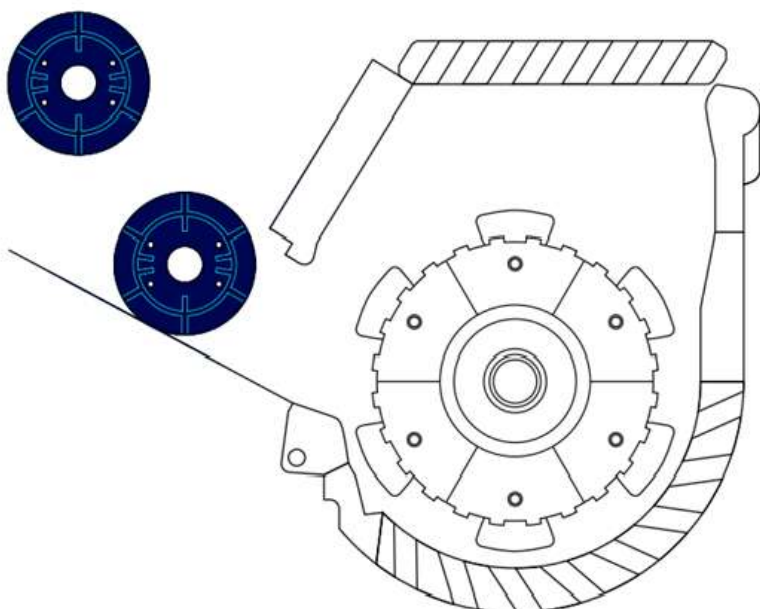

Recuperação do Perfil:
GMW FC 70T-4
Revestimento Anti Abrasão:
GMW XTRA 600 TIC OA

Bigorna

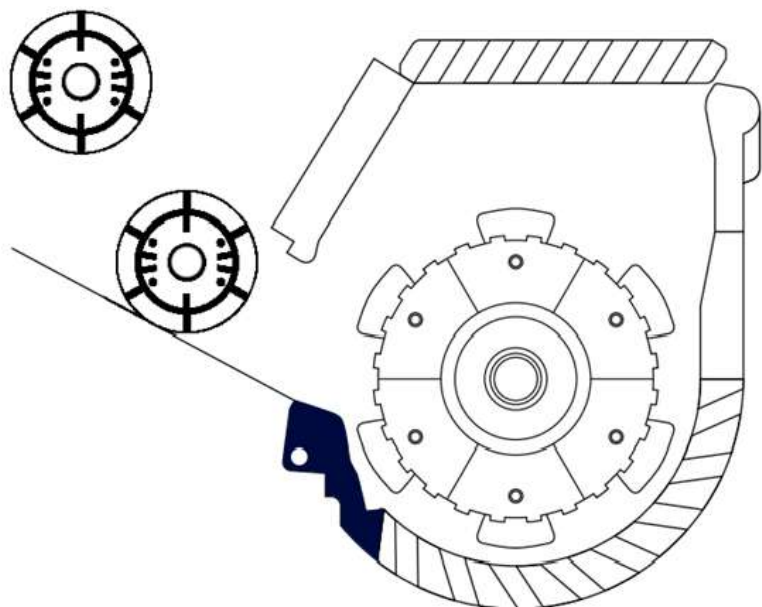

Recuperação:
GMW XTRA HAMMER MN OA

Placa Anti Abrasão

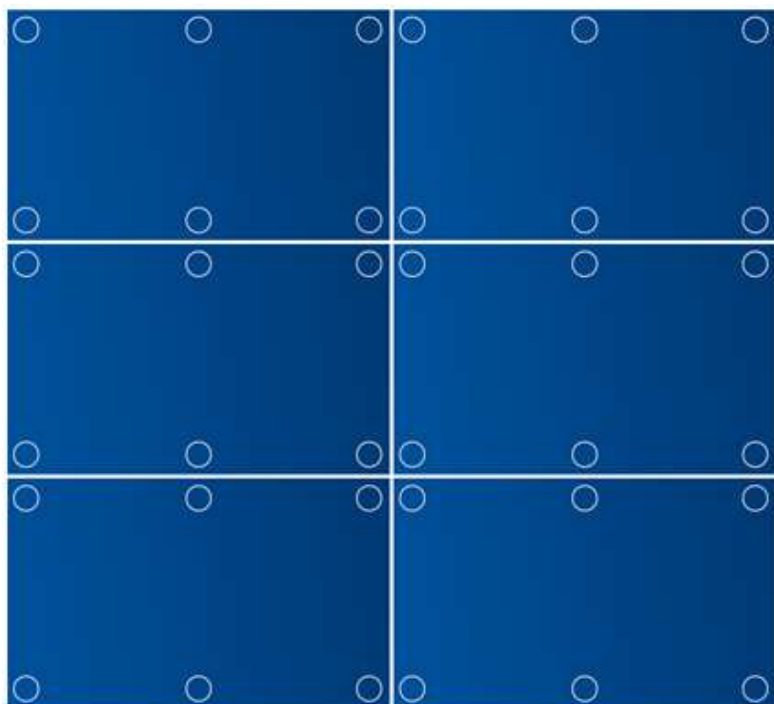

Recuperação:
GMW ARC-PLATE

Grelha

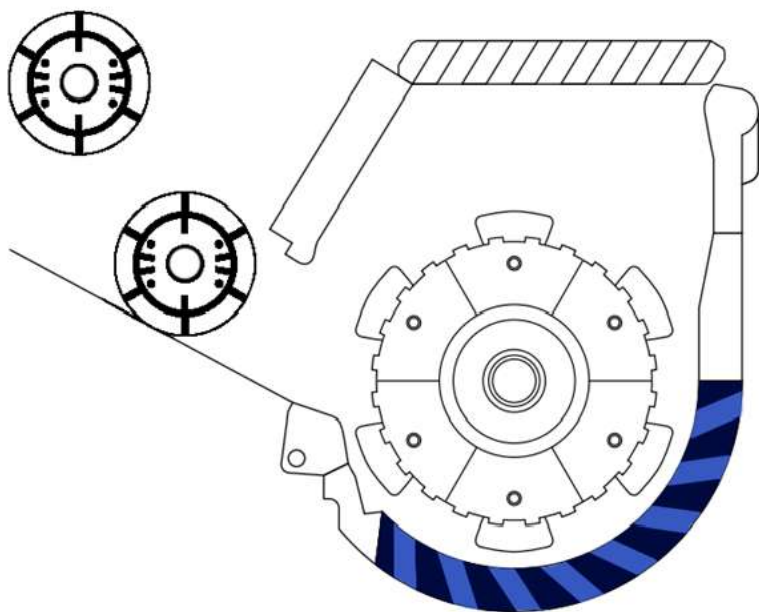

Preventivo/Recuperação:
GMW XTRA 600 TIC OA

Contra-Chapa

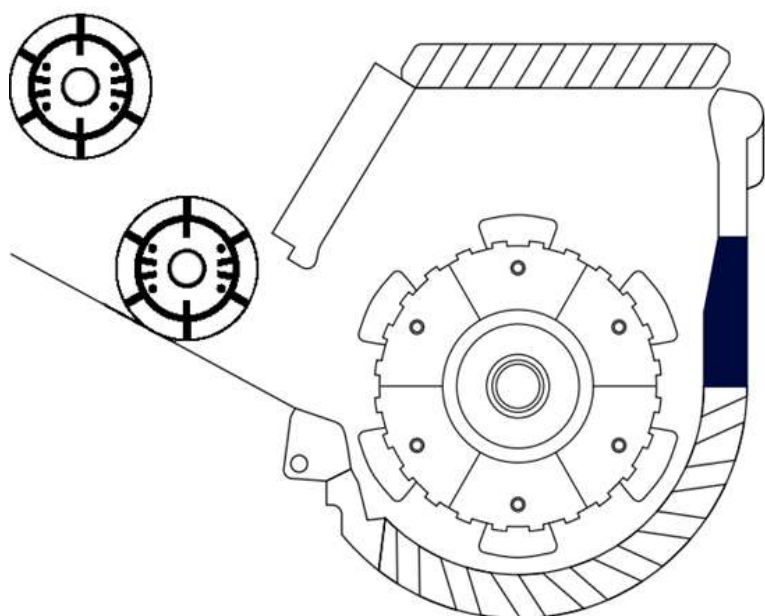

Preventivo/Recuperação:
GMW XTRA 600 TIC OA

Grelha Superior

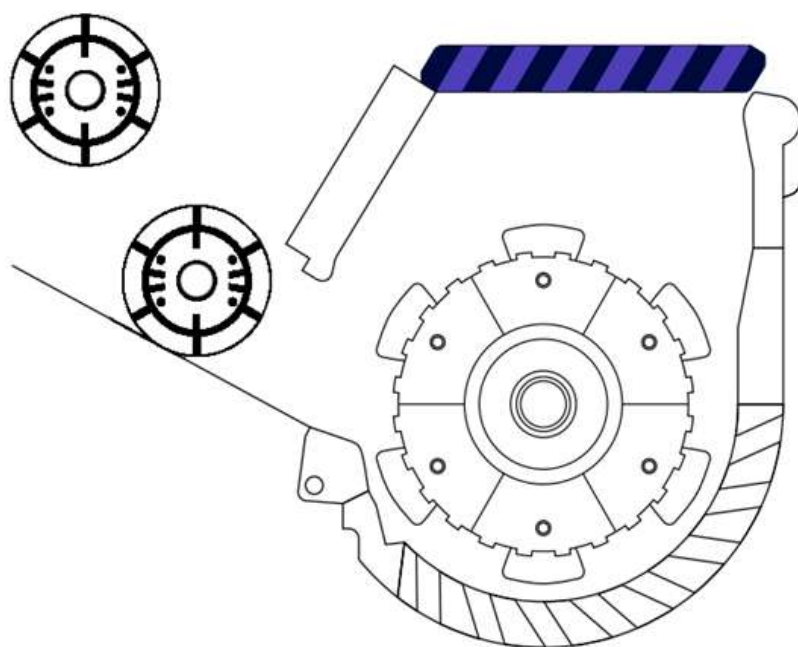

Preventivo/Recuperação:
GMW XTRA 600 TIC OA

Tabela Consumíveis

PRODUTO	C	Mn	Si	Cr	Mo	Ti	Nb	Al	Ni	DUREZA
GMW 110 MC	0,050	1,60	0,40	0,50	0,50	-	-	-	2,20	
GMW FC 70T-4	0,25	0,40	0,20	-	-	-	-	1,50	-	
GMW XTRA 600 MC	0,60	1,30	1,20	7,00	1,00	-	-	-	-	56-60 HRC
GMW HAMMER MN OA	0,90	14,00	0,80	3,50	-	-	-	-	-	200 HB
GMW XTRA HAMMER MN OA	0,50	14,00	0,50	4,00					0,60	200 - 450 HB
GMW XTRA 600 TIC OA	1,80	1,20	0,70	6,50	0,80	5,00	-	-	-	56-60 HRC
GMW ARC-PLATE	4,50	1,00	1,50	27,50	-	-	1,00	-	-	56-60 HRC



GMW

WELDING

Welding Consumables
Consumibles para Soldadura
Consumíveis de Soldagem

www.gmw.com.br
11 2211-4441

